



Edition : 2.0
Date: (10/24)

INSTRUCTION MANUAL

MOTORISED PLATE CURVING ROLLS

PR-133A, PR-134A, PR-136A, PR-204A

Order Code: (S802, S803, S804, S805)

MACHINE DETAILS

MACHINE.	PLATE CURVING ROLLS
MODEL NO.	PR-SERIES
SERIAL NO.	
DATE OF MANF.	

IMPORTED BY

AUSTRALIA



www.machineryhouse.com.au

NEW ZEALAND



www.machineryhouse.co.nz

NOTE:

This manual is only for your reference. At the time of the compiling of this manual every effort to be exact with the instructions, specifications, drawings, and photographs of the machine was taken. Owing to the continuous improvement of the HAFCO METALMASTER machine, changes may be made at any time without obligation or notice. Please ensure the local voltage is the same as listed on the specification plate before operating any electric machine.

SAFETY SYMBOLS:

The purpose of safety symbols is to attract your attention to possible hazardous conditions



WARNING

Indicates a potentially hazardous situation causing injury or death



CAUTION

Indicates an alert against unsafe practices.

Note: Used to alert the user to useful information.

NOTE:

In order to see the type and model of the machine, please see the specification plate. Usually found on the back of the machine. See example (Fig.1)

HAFCO METALMASTER	
PRODUCT SPECIFICATIONS	
Model: PR	Voltage: 415V/50Hz
Capacity:	Motor:
Nett Weight:	FLC:
MFG Date:	
Serial No:	
Imported by www.machineryhouse.com.au	Made in China www.machineryhouse.co.nz

Fig.1

CONTENTS:

1. GENERAL MACHINE INFORMATION	
1.1 Specifications.....	4
1.2 Standard Equipment.....	4
1.3 Identification.....	5
2. IMPORTANT INFORMATION	
2.1 General Metalworking Machine Safety.....	6
2.2 Specific Safety For Rolling Machines.....	9
3. POWER SUPPLY	
3.1 Electrical Requirements.....	10
3.2 Full Load Current Rating.....	10
4. SETUP	
4.1 Unpacking.....	11
4.2 Clean-Up.....	11
4.3 Site Preparation.....	11
4.4 Lifting Instructions.....	12
4.5 Anchoring To The Floor.....	13
4.6 Machine Levelling.....	13
4.7 Checking the Power Supply.....	14
5. OPERATION	
5.1 Controls.....	15
5.2 Resetting Safety Wire.....	16
5.3 Operation Overview.....	17
5.4 Releasing The Swinging Roller.....	17
5.5 Resetting The Zero Position.....	18
6. MAINTAINANCE	
6.1 Schedule.....	19
6.2 Lubrication Points.....	19
6.3 Adjusting The Safety Wire.....	20
6.4 Adjusting Bending Roll Parallelism.....	21
6.5 Troubleshooting.....	22
SPARE PARTS.....	23
Risk Assessment Sheets.....	28

1.1 SPECIFICATIONS

Order Code	S802	S803	S804	S805
Model	PR-133A	PR-134A	PR-136A	PR-204A
Max rolling width	1300	1300	1300	2000
Max. rolling thickness {Mild steel}	2.5mm	4.0mm	6.5mm	4.0mm
Rolling Diameter	90mm	120mm	150mm	150mm
Rotating Speed	12 rpm	10 rpm	7 rpm	7 rpm
Motor Power	Main 1.1kW	Main 2.2kW	Main 2.2kW	Main 2.2kW
	Bending 1.1kW	Bending 1.1kW	Bending 1.5kW	Bending 1.5kW
Voltage	415	415	415	415
Overall Dimension	177x126x97cm	177x126x101cm	193x125x114cm	253x126x120cm
Weight	655 kg	865 kg	1330 kg	1575 kg

1.2. STANDARD EQUIPMENT

- Tools
- Instruction Manual
- Foot switch and control panel

NOTE:

The above specifications were current at the time this manual was published, but because of our policy of continuous improvement, Metalmaster reserves the right to change specifications at any time and without prior notice, without incurring obligations.



WARNING

The machine is the sole responsibility of the owner for its safe use. This responsibility includes but is not limited to proper installation in a safe environment, personnel operator training, proper inspection and maintenance, manual availability and comprehension. The manufacturer will not be held liable for injury or property damage from negligence, improper training, machine modifications or misuse.

1.3 IDENTIFICATION

Become familiar with the names and locations of the controls and features shown below to better understand the instructions when mentioned later in this manual.

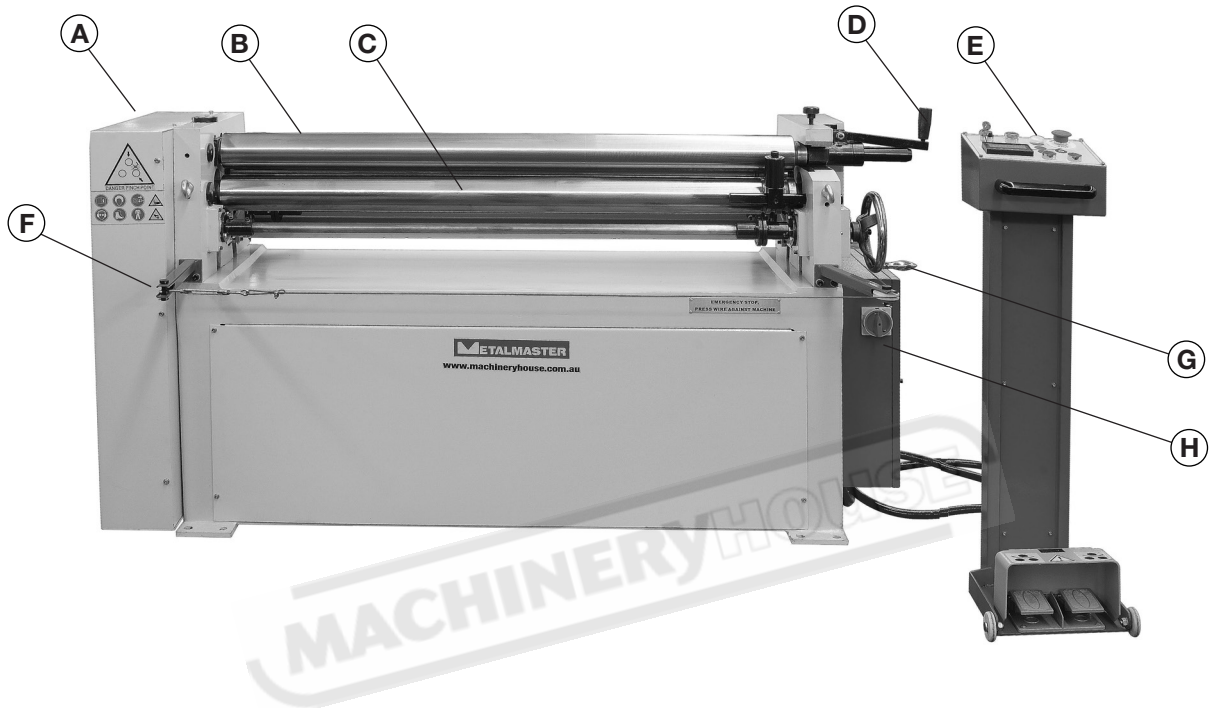

A	Gear Cover	E	Pedestal Control Panel
B	Top Roller	F	Safety Cable
C	Bottom Roller	G	Thickness Handle
D	Upper Roller Release Handle	H	Electrical Box

2. IMPORTANT INFORMATION

2.1 GENERAL METALWORKING MACHINE SAFETY

DO NOT use this machine unless you have read this manual or have been instructed in the use of this machine in its safe use and operation



WARNING

This manual provides safety instructions on the proper setup, operation, maintenance, and service of this machine. Save this manual, refer to it often, and use it to instruct other operators. Failure to read, understand and follow the instructions in this manual may result in fire or serious personal injury—including amputation, electrocution, or death.

The owner of this machine is solely responsible for its safe use. This responsibility includes, but is not limited to proper installation in a safe environment, personnel training and authorization to use, proper inspection and maintenance, manual availability and comprehension, of the application of the safety devices, integrity, and the use of personal protective equipment.

The manufacturer will not be held liable for injury or property damage from negligence, improper training, machine modifications or misuse.



- ✓ Always wear safety glasses or goggles.
- ✓ Wear appropriate safety footwear.
- ✓ Wear respiratory protection where required.
- ✓ Gloves should never be worn while operating the machine, and only worn when handling the workpiece.
- ✓ Wear hearing protection in areas > 85 dBA. If you have trouble hearing someone speak from one metre (three feet) away, the noise level from the machine may be hazardous.
- ✓ DISCONNECT THE MACHINE FROM POWER when making adjustments or servicing.
- ✓ Check and adjust all safety devices before each job.
- ✓ Ensure that guards are in position and in good working condition before operating.
- ✓ Ensure that all stationary equipment is anchored securely to the floor.
- ✓ Ensure all machines have a start/stop button within easy reach of the operator.
- ✓ Each machine should have only one operator at a time. However, everyone should know how to stop the machine in an emergency.

2.1 GENERAL SAFETY REQUIREMENTS CONT.

- ✓ Ensure that keys and adjusting wrenches have been removed from the machine before turning on the power. Appropriate storage for tooling should be provided.
- ✓ Ensure that all cutting tools and blades are clean and sharp. They should be able to cut freely without being forced.
- ✓ Stop the machine before measuring, cleaning or making any adjustments.
- ✓ Wait until the machine has stopped running to clear cuttings with a vacuum, brush or rake.
- ✓ Keep hands away from the cutting head and all moving parts.
- ✓ Avoid awkward operations and hand positions. A sudden slip could cause the hand to move into the cutting tool or blade.
- ✓ Return all portable tooling to their proper storage place after use.
- ✓ Clean all tools after use.
- ✓ Keep work area clean. Floors should be level and have a non-slip surface.
- ✓ Use good lighting so that the work piece, cutting blades, and machine controls can be seen clearly. Position any shade lighting sources so that they do not cause any glare or reflections.
- ✓ Ensure there is enough room around the machine to do the job safely.
- ✓ Obtain first aid immediately for all injuries.
- ✓ Understand that the health and fire hazards can vary from material to material. Make sure all appropriate precautions are taken.
- ✓ Clean machines and the surrounding area when the operation is finished.
- ✓ Use proper lock out procedures when servicing or cleaning the machines or power tools.

DO NOT

- × Do not distract an operator. Horseplay can lead to injuries and should be strictly prohibited.
- × Do not wear loose clothing, gloves, neckties, rings, bracelets or other jewellery that can become entangled in moving parts. Confine long hair.
- × Do not handle cuttings by hand because they are very sharp. Do not free a stalled cutter without turning the power off first. Do not clean hands with cutting fluids.
- × Do not use rags or wear gloves near moving parts of machines.
- × Do not use compressed air to blow debris from machines or to clean dirt from clothes.
- × Do not force the machine. It will do the job safer and better at the rate for which it was designed.

2.1 GENERAL SAFETY REQUIREMENTS CONT.

HAZARDS ASSOCIATED WITH MACHINES include, but are not limited to:

- Being struck by ejected parts of the machinery
- Being struck by material ejected from the machinery
- Contact or entanglement with the machinery
- Contact or entanglement with any material in motion

Health Hazards (other than physical injury caused by moving parts)

- Chemicals hazards that can irritate, burn, or pass through the skin
- Airborne items that can be inhaled, such as oil mist, metal fumes, solvents, and dust
- Heat, noise, and vibration
- Ionizing or non-ionizing radiation (X-ray, lasers, etc.)
- Biological contamination and waste
- Soft tissue injuries (for example, to the hands, arms, shoulders, back, or neck) resulting from repetitive motion, awkward posture, extended lifting, and pressure grip.

Other Hazards

- Slips and falls from and around machinery during maintenance
- Unstable equipment that is not secured against falling over
- Safe access to/from machines (access, egress)
- Fire or explosion
- Pressure injection injuries from the release of fluids and gases under high pressure
- Electrical Hazards, such as electrocution from faulty or ungrounded electrical components
- Environment in which the machine is used (in a machine shop, or in a work site)



WARNING

The machine is the sole responsibility of the owner for its safe use. This responsibility includes but is not limited to proper installation in a safe environment, personnel training, proper inspection and maintenance, manual availability and comprehension. The manufacturer will not be held liable for injury or property damage from negligence, improper training, machine modifications or misuse.



WARNING!

Machines are safeguarded to protect the operator from injury or death with the placement of guards. Machines must not be operated with the guards removed or damaged.

2.2 SPECIFIC SAFETY FOR ROLLING MACHINES

DO NOT use this machine unless you have been instructed in its safe use and operation and have read and understood this manual



Safety glasses must be worn when operating this equipment



Long and loose hair must be contained when operating this equipment.



Safety footwear must be worn when operating this equipment



Close fitting/protective clothing must be worn when operating the machine



Rings and jewellery must not be worn when operating this machine



Hearing protection must be used when operating in a noisy environment

PRE-OPERATIONAL SAFETY CHECKS

- ✓ Locate and ensure you are familiar with all machine operations and the controls.
- ✓ Ensure all guards are fitted, secure and functional. Do not operate if guards are missing or faulty.
- ✓ Working parts should be well lubricated and the rolls are free of rust and dirt.
- ✓ Check workspaces and walkways to ensure no slip/trip hazards are present.
- ✓ Be aware of other people in the area and ensure the area is clear before using equipment.

OPERATIONAL SAFETY CHECKS

- ✓ Adjust the chosen rollers slowly and in small adjustments.
- ✓ Take care during the initial feeding of the workpiece into the rollers.
- ✓ Hold the workpiece sufficiently far back from the edge being fed into the rolls, to allow for the infeed speed of the machine.
- ✓ Adjust the rollers at a slow even rate. Be aware of rotating rolls
- ✓ Only one person may operate this machine at any one time.

ENDING OPERATIONS AND CLEANING UP

- ✓ Ensure the machine is left in a safe condition after use.
- ✓ Leave the work area in a safe, clean and tidy state.

POTENTIAL HAZARDS AND INJURIES

- ✓ Sharp edges and burrs.
- ✓ Crush and pinch points.
- ✓ Hair/clothing getting caught in moving machine parts.
- ✓ Operator's hands may be caught and drawn into the rolls.

DON'T

- × Do not use faulty equipment. Immediately stop and repair suspect machinery.
- × Do not attempt to roll material beyond the capacity of the machine.

3. POWER SUPPLY

3.1 ELECTRICAL REQUIREMENTS

Place the machine near an existing power source. Make sure all power cords are protected from traffic, material handling, moisture, chemicals, or other hazards. Make sure there is access to a means of disconnecting the power source. The electrical circuit must meet the requirements for 415V. To minimize the risk of electrocution, fire, or equipment damage, these machines should be hard wired with installation work and electrical wiring done by a qualified electrician.

NOTE : The use of an extension cord is not recommended as it may decrease the life of electrical components on your machine.

ELECTRICAL REQUIREMENTS

Nominal Voltage.....	415V
Cycle.....	50 Hz
Phase.....	Three Phase
Power Supply Circuit.....	15 Amps
Full Load Current.....	(See Motor Plate)

(Full load current rating is also on the specification plate on the motor.)

3.2 FULL-LOAD CURRENT RATING

The full-load current rating is the amperage a machine draws when running at 100% of the output power. Where machines have more than one motor, the full load current is the amperage drawn by the largest motor or a total of all the motors and electrical devices that might operate at one time during normal operations.

Full-Load Current Rating for these machine can be found on the motor nameplate.

It should be noted that the full-load current is not the maximum amount of amps that the machine will draw. If the machine is overloaded, it will draw additional amps beyond the full-load rating and if the machine is overloaded for a long period of time, damage, overheating, or fire may be caused to the motor and circuitry. This is especially true if connected to an undersized circuit or a long extension lead. To reduce the risk of these hazards, avoid overloading the machine during operation and make sure it is connected to a power supply circuit that meets the requirements.



WARNING

These machines must be connected to a permanent earth wiring system. Due to the complexity and high voltage, the installation MUST be done by a qualified electrician.

4 SET-UP

4.1 UNPACKING

This machine was carefully packaged for safe transport. When unpacking, separate all enclosed items from packaging materials and inspect them for shipping damage. If items are damaged, please contact your distributor.

NOTE: Save all the packaging materials until you are completely satisfied with the machine and have resolved any issues with the distributor, or the shipping agent.

When unpacking, check the packing list to make sure that all parts shown are included. If any parts are missing or broken, please contact your distributor.

4.2 CLEAN - UP

The unpainted surfaces of the machine have been coated with a waxy oil to protect them from corrosion during shipment. Remove the protective coating with a solvent cleaner or a citrus based degreaser.

Optimum performance from your machine will be achieved when you clean all moving parts or sliding contact surfaces that are coated with rust preventive products.

It is advised to avoid chlorine based solvents, such as acetone or brake parts cleaner, as they will damage painted surfaces and strip metal should they come in contact. Always follow the manufacturer's instructions when using any type of cleaning product.

4.3 SITE PREPARATION

When selecting the site for the machine, consider the largest size of workpiece that will be processed through the machine and provide enough space around the machine for operating the machine safely. Consideration should be given to the installation of auxiliary equipment. Leave enough space around the machine to open or remove doors/covers as required for the maintenance and service as described in this manual.

It is recommended that the machine is anchored to the floor to prevent tipping or shifting. It also reduces vibration that may occur during operation.

Before securing the machine a solid concrete base must be prepared to the specification of the machine.

The sizes for the bolt holes position are listed as A-B. (Check with your dealer before the machine arrives) (Fig. 4.1)

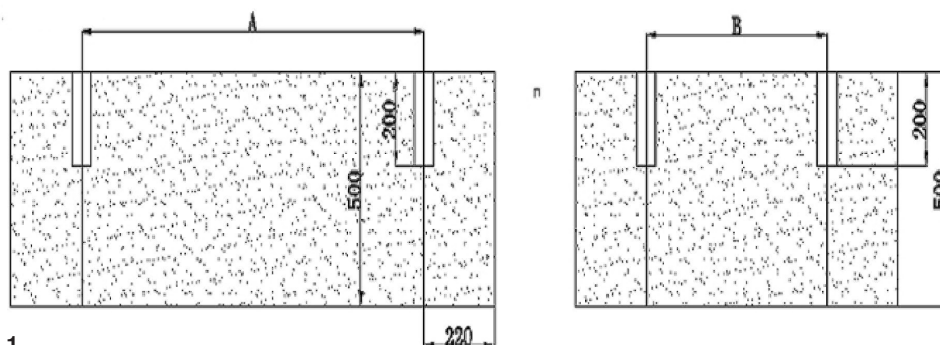

Fig. 4.1

4.4 LIFTING INSTRUCTIONS

- The lifting device should be capable of lifting the weight of the machine.
- Before using the equipment inspect them to ensure that they are in good condition and are certified
- If using slings, they must be arranged correctly so the machine is lifted level.

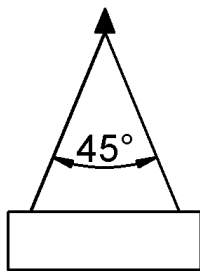

FIG 4.2.

When the slings are at a 45° angle then each sling is carrying the equivalent of 50% of load weight. (Fig.4.2).

When the slings are at a 90° angle then each sling will have a weight equal to 75% of the load on each sling. (Fig 4.3)

NOTE: The manufacturer recommends not to exceed 90° angle

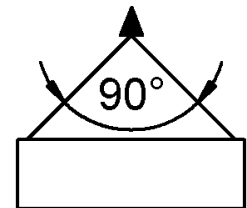

FIG 4.3

- The lifting device operator should be a qualified & trained person in rigging and lifting. The machine can also be lifted with a forklift.



WARNING

When lifting with a forklift observe the following.

- The forklift's capacity is the maximum weight it can safely carry at a specified load center. Check the load capacity data plate on the forklift to ensure that the load does not exceed the capacity.
- The forklift operator must be licensed to operate the forklift
- Make sure the tynes of the forklift are protruding through the other side of the machine before lifting. (Fig 4.4)



FIG. 4.4

4.5 ANCHORING TO THE FLOOR

The machine is best mounted on a concrete slab. Masonry anchors with bolts are the best way to anchor machinery, because the anchors sit flush with the floor surface, making it easy to unbolt and move the machine later if needed. (Fig. 4.5)

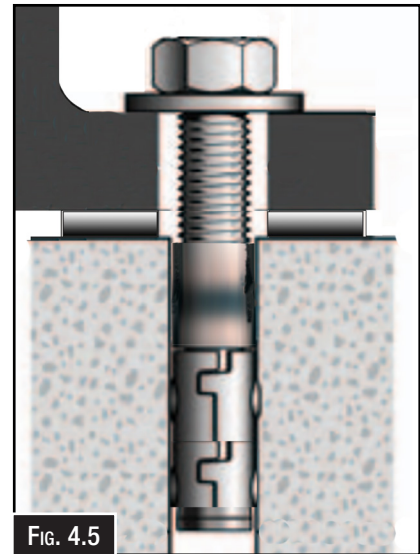

FIG. 4.5

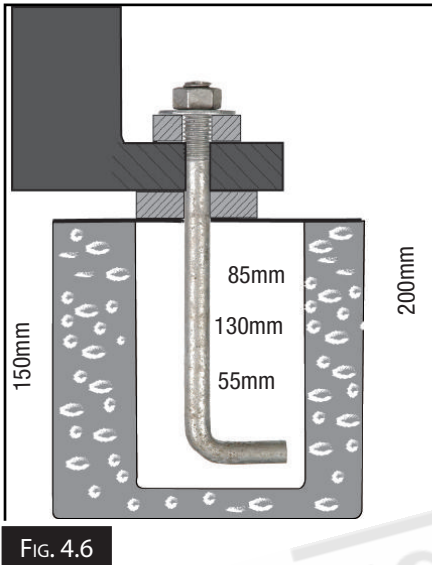

FIG. 4.6

In some case a suitable foundation may not be available and a new one may need to be prepared. The foundation should be concrete approximately 250mm thick with pockets left clear for the hold down bolts. The hold down bolts can be "L" shape as per the example in Fig. 4.6

4.6 MACHINE LEVELLING

To set your machine up so that it operates to optimum performance, apply the following procedure.

After your machine has been anchored to a concrete slab floor, it then needs to be levelled. Loosen the hold down bolts and place a level on the surface of the working table. Metal shims need to be placed under the corner of the base of the machine until level. Once level then tighten the hold down bolts. (Fig. 4.7).

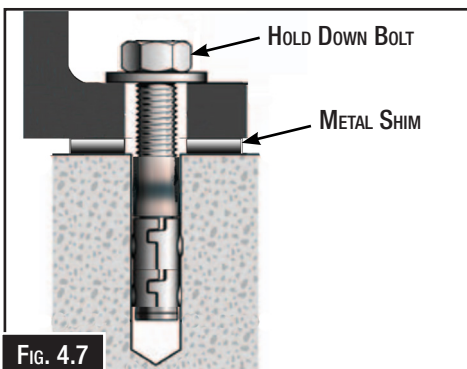

FIG. 4.7



CAUTION

The machine must not rest on supports other than those defined in Fig. 4.7

4.7 CHECKING THE POWER SUPPLY

METALMASTER machines are supplied wired ready to run. Check the specification plate on the machine to confirm the correct voltage of the power supply.

The machine must be connected by a qualified and licensed electrician. Warranty could be void if it is found that the connection was not carried out by a qualified electrician.

Once connected, check the up and down movement of the back roller (Fig. 4.9) by depressing buttons 6 or 7. (Fig. 4.8) The roller needs to travel in the same direction as the symbol on the button depressed.

If the direction is incorrect, isolate the machine and have the electrician make changes to the wiring.



FIG. 4.8

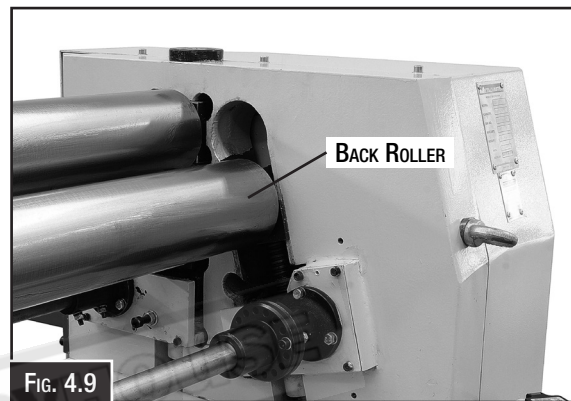

FIG. 4.9

4.8 COMMISSIONING CHECK LIST.

Before starting the machine the following checks must be carried out.

- Installation and machine preparation has been performed according to the manuals instructions.
- All grease nipple points have been lubricated.
- Electrical earth fitted and power circuits, switches, and foot-pedal checked.
- Check power connections and any damage to wiring.
- Safety guards have been fitted securely
- Check motor rotation.
- Test Emergency stop to ensure it is operating correctly.
- Test Emergency wire stop to ensure it is operating correctly.
- Test controller operation.
- Test all mechanical operations on the machine.
- Test roll material and check quality of the rolling.
- Tools, equipment and personnel are clear of the machine.
- Operation Manual on how to operate the machine has been read.

Testing The Emergency Stop Button

Make sure that the emergency button is working correctly

1. Twist the top of the Emergency Stop button to ensure that it is in the raised position.
2. Start the machine and then press the emergency stop button. The machine should stop and the power should be cut off. If the machine cannot be started then the emergency stop is working correctly.
3. To reset the Emergency Stop twist the red top until it pops up. The machine should now work again.



5. OPERATION

This machine may perform many types of operations that are beyond the scope of this manual. Many of these operations may be dangerous or deadly if performed incorrectly.

The instructions in this section are written with the understanding that the operator has the necessary knowledge and skills to operate this machine. If at any time you are experiencing difficulties performing any operation, stop using the machine!

If you are an inexperienced operator, we strongly recommend that you read books, trade articles, or seek training from an experienced operator before performing any unfamiliar operations. **Above all, your safety should come first!**

5.1 CONTROLS

The purpose of this control overview is to provide the novice machine operator with a basic understanding of how the machine is used during operation, and the machine controls and what they do. It also helps the operator to understand if they are discussed later in this manual.

NOTE: DO NOT start the machine until all of the setup instructions have been performed.

Pedestal Control Panel (Fig. 5.1)

1. **Key Lock:** Locks the isolating switch to stop power to the machine.
2. **Start Button:** Activates the power to the control circuit.
3. **Power Lamp:** Indicates that power is ON.
4. **Emergency Stop Button:** When pressed cuts power to the machine. Power can only be restored when the button is reset.
5. **Digital Display:** Displays the position of the rear roller.



FIG. 5.1

6. **Down Button:** When pressed and held moves the rear roller in a downward motion
7. **Up Button:** When pressed and held, moves the rear roller in an upward motion.

Foot Pedals (Fig. 5.2)

8. **Clockwise Pedal:** When pressed and held, rotates the rollers clockwise
9. **Counter Clockwise Pedal:** When pressed and held, rotates the rollers counter clockwise.



FIG. 5.2

Controls (Fig. 5.3)

- 10. **Top Roller Handle:** Used to move the top roller.
- 11. **Thickness Handle:** Adjust the thickness of the material.
- 12. **Conical Bending Guide:** Guides the material when using the wire grooves.
- 13. **Top Roller Lock:** Locks the top roller in place when the rolling operation is carried out.
- 14. **Safety Wire:** When the wire is pressed against, the machine stops.
- 15. **Isolating Switch:** Isolates the power from the machine.

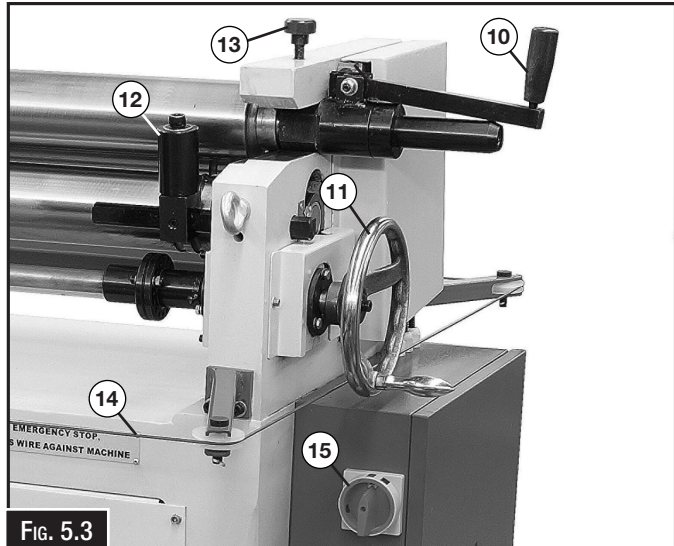

Fig. 5.3

Wiring Grooves (Fig. 5.4)

- 16. **Wiring Grooves:** Used to roll wire and small round stock.

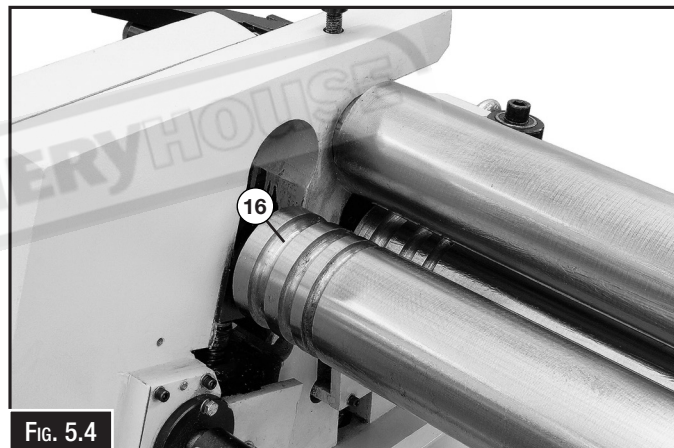

Fig. 5.4

5.2 RESETTING SAFETY WIRE

This Metalmaster Rolling machine is fitted with a safety Emergency Stop in the form of a red wire that is around the machine. (Fig. 5.5) Pressing against this wire with any part of your body will cut the power to the machine. Safety signs have been placed around the machine to remind the operator of this Emergency Stop. Once the wire has been pressed the emergency switch needs to be reset. To do this the pin on the Emergency Safety micro switch needs to be raised. (See Fig 5.6)



Fig. 5.5

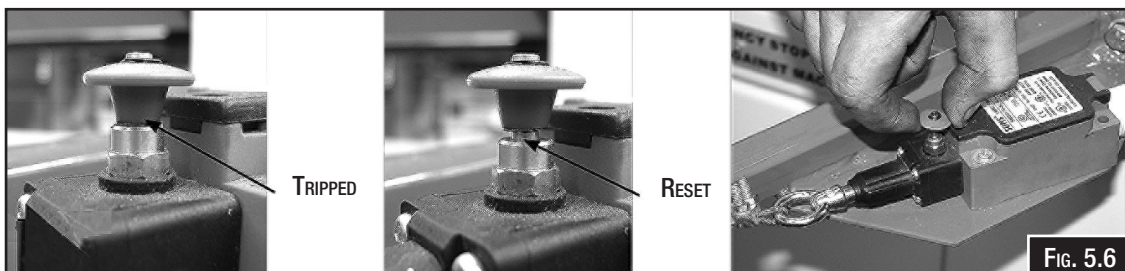

Fig. 5.6

5.3 OPERATION OVERVIEW

The purpose of the overview is to provide the novice machine operator the basic understanding of how the machine is used during operation, so the machine operating controls discussed later in this manual are easily understood. The generic nature of this overview, is not intended to be an instructional guide. Metalmaster suggests that for more specific information the operator should, read this manual, seek additional training from an experienced machine operator, and read “how-to” books, trade magazines, or view websites.

Start Up

- Check that the electrical supply has been connected.
- Check that the Emergency safety wire has been reset.
- Ensure that the emergency stop button is in the released position.
- Ensure the isolating switch is on and power light is illuminated.
- Press the start button to commence operation.

Rolling

- Place the steel plate in the machine and adjust the clamping roller using the hand wheel (Fig. 5.7) to suit the plate thickness.
- Once the steel plate is in position for rolling then depress the pedal to move the plate in the direction required.
- In slow increments move the rear roller up to create curve or cylinder.
- Do not roll material which has been welded or deformed.

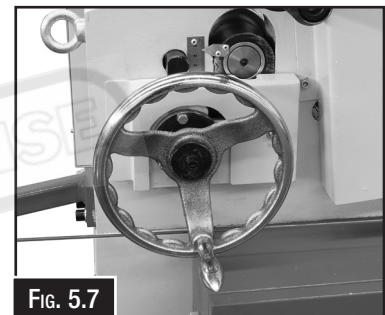

5.4 RELEASING THE SWINGING ROLLER

The material once rolled will need to be removed from the rolls. To do this one of the rollers can be released at one end and the other end swings away from the machine. The picture in Fig. 5.8 shows the swinging roller handle.

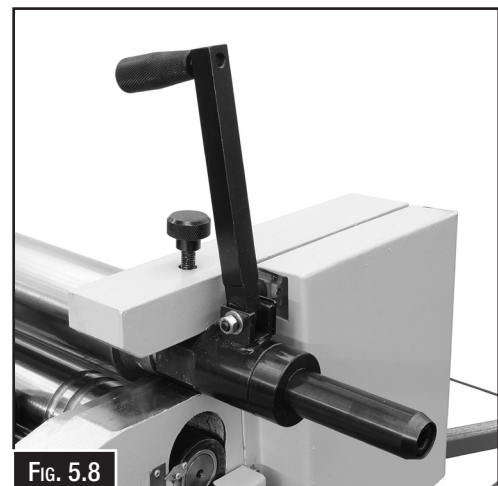

1. Rotate release lever lock knob counterclockwise until upper roller release lever can be pulled down, and flat edges of upper roller bracket are parallel with slots in frame. The micro switch is now released and the power is disconnected. (Fig.5.8)
2. Pull the top roller out of the frame and remove the workpiece. (Fig. 5.9)
3. Rotate lever upward to its vertical position and tighten lock knob to secure upper roller
4. Slide upper roller out from frame, remove workpiece from upper roller, then slide top roller back into frame and lock. (Fig. 5.10)

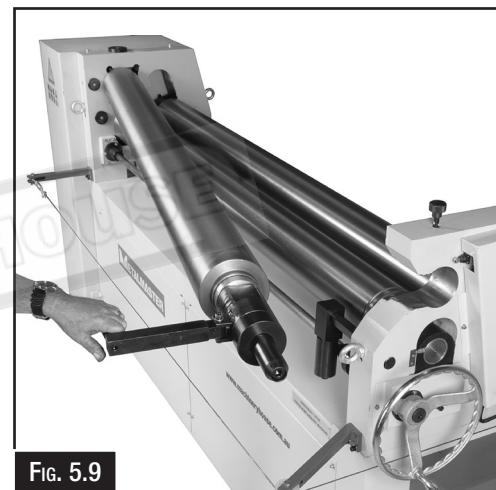
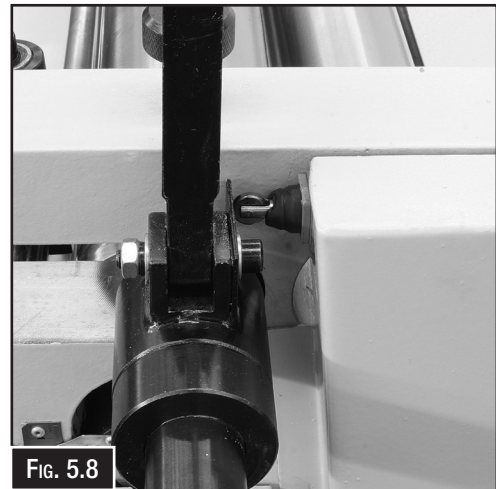

5.5 RESETTING THE ZERO POSITION

If the zero position is lost, the bottom roller may not be able to travel to the maximum opening capacity.

To set zero on the counter press arrow up (A in Fig.5.11) once. This will set the zero limit position and J2 will be illuminated. Bending roller cannot be driven down past zero.

To reset the zero position, press and hold arrow up (A in Fig.5.11) . This will disarm bottom limit so the bending roll can be driven down past zero. The bending roller can now be driven down until the safety limit switch is activated.

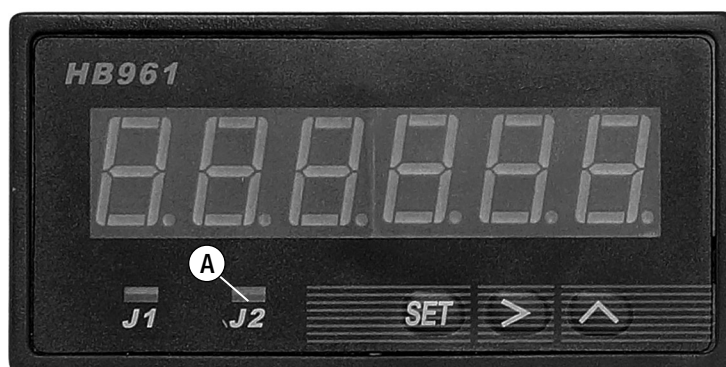

6. MAINTENANCE

It is very important that regular maintenance of the equipment is carried out. The operators need to follow the daily maintenance procedures.

For optimum performance from this machine, the maintenance schedule listed below and in this section must be followed.

6.1 SCHEDULE

Daily Check

- Loose mounting bolts or fasteners.
- Cracked or damaged rollers, fingers and blade.
- Any other condition that could hamper the safe operation of this machine

Weekly Check

- Clean machine
- Lubricate gears
- Lubricate roller bushings

6.2 LUBRICATION POINTS

The machine needs to be lubricated with 30W oil.
Please see the daily lubrication points below.
(Fig.6.1)

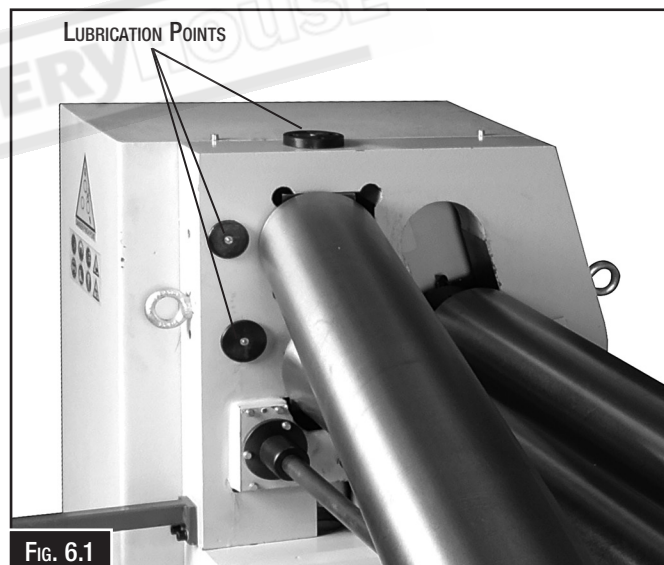

WARNING

*Disconnect all power from the machine before servicing.
There may be multiple power sources present.
Remove the plug from the power point or remove the fuse if
hardwired. Failure to do so may cause death or injury.*

6.3 ADJUSTING THE SAFETY WIRE SWITCH

The Emergency Safety Stop has been set by the factory but the wire may need to be re-tensioned at some time during the life of the machine. Below is the procedure for setting the micro switch that operates the Emergency Safety Stop wire.

Step 1.

Locate the micro switch and check the shaft of the switch for the position of the black ring on the shaft.

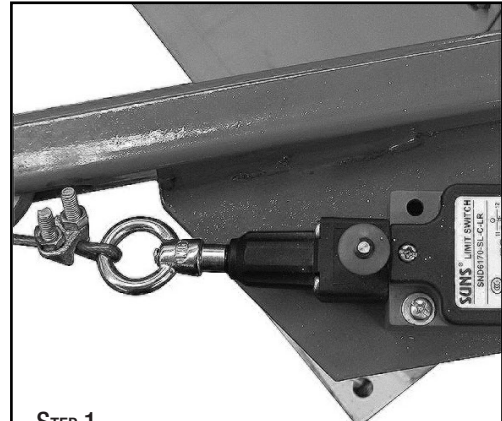

Step 2.

The correct position of the black ring on the shaft should be level with the end of the shaft housing.

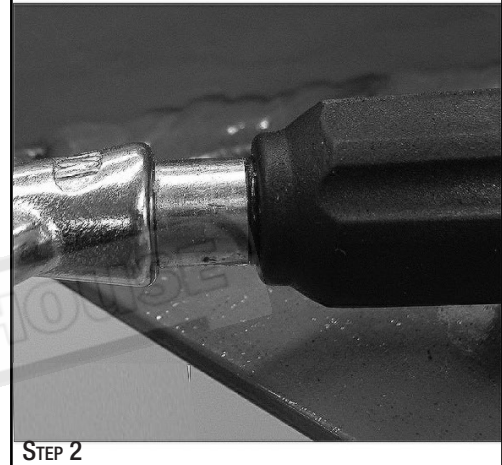

Step 3.

In the picture shown as the black ring has been pulled past the end of the shaft housing indicating that the wire has been tensioned too tight.

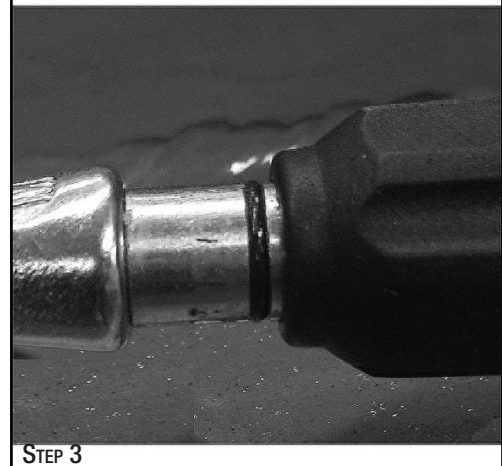

Step 4.

Loosen and adjust the turnbuckle until the black ring on the shaft is level with the end of the shaft housing.

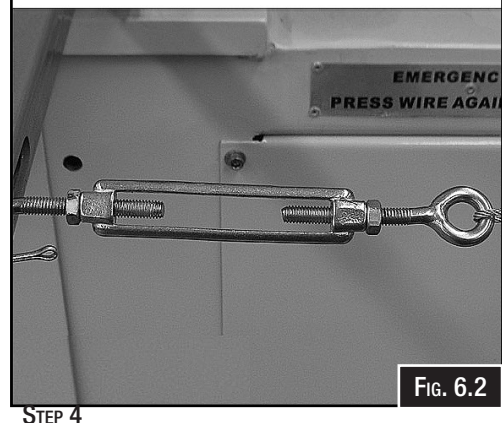

Fig. 6.2

6.4 ADJUSTING BENDING ROLL PARALLELISM.

If the finished work piece has not rolled parallel then adjustment will need to be made to bring the bending roller parallel to the pinch roller. The following procedure allows for this change.

STEP 1.

Locate the shaft that lowers and raises the bending roll on the front of the machine.

(See Fig.6.3)

Mounted on the shaft is a coupling with multiple holes.

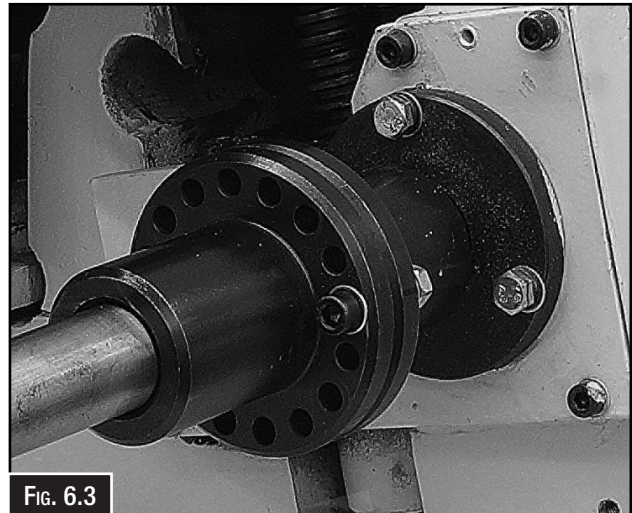

Fig. 6.3

Step 2.

To adjust, remove the bolt and rotate the coupling until the travel of the bending roll is parallel with the pinch roller. (Fig. 6.4). Once parallel then insert the bolt and tighten.



Fig. 6.4



WARNING.

Take care when operating this machine. Crush Points can occur when operating this machine. Crush points can cause severe injury to the operator. All care must be taken.



CAUTION

Before attempting this feature, disconnect the machine from the power supply to avoid injury to the operator from accidental startup or damage to the machine

6.5 TROUBLESHOOTING

Review the troubleshooting and procedures in this section if a problem develops with your machine. If you need replacement parts then follow the procedure in the beginning of the spare parts section or if additional help with a procedure is required, then contact your distributor.

Note: Make sure you have the model of the machine, serial number, and manufacture date before calling.

Symtoms	Possible Cause	Possible Solution
Inaccurate Bending	More material thickness settings may be needed to make consistent bends.	One should check and adjust the material thickness settings to ensure they are correct.
	Worn-out rolls disrupt the machine's ability to form materials accurately.	Inspect the rolls for any signs of wear and tear that could impair function.
	A machine that is not correctly calibrated may deviate from the intended parameters.	Calibrate the machine thoroughly to align with precise bending requirements.
Machine Vibrations or Noise	Mismatched parts may lead to pronounced vibration and noise.	All bolts and screws should be tightened by operators to secure machine components.
	Rolls misalignments disrupt the smooth operation of the machine.	To ensure proper functioning, rolls are to be aligned per the manufacturer's instructions.
	Inadequate lubrication causes more friction and noise.	All moving parts should be properly lubricated to minimize noise.
Uneven Rolling and End Flare	Misalignment of rolls leads to uneven material processing.	Adjust the roll gap for even material distribution across the machine.
	Incorrectly set roll gap disrupts material flow and thickness.	Check and correct roll alignment to ensure consistent product quality.
Slip or Skidding and Wrinkling	An overloaded machine can cause the material to slip or wrinkle.	Avoid overloading the machine to prevent material distortion.
	Insufficient tension may not hold the material firmly, leading to slip.	Regularly clean roll surfaces to maintain effective grip and prevent slip.
	Surface contamination reduces grip, increasing the likelihood of skidding	Ensure tension settings are appropriate for the material and load.
Electrical or Control System Malfunctions	Faulty wiring or connections can interrupt system functionality.	Conduct thorough inspections and repair any electrical connections.
	Malfunctioning control units may lead to erratic machine behavior.	Test and reset control systems to ensure they are functioning properly.



WARNING.

Loose hair, clothing, or jewellery could get caught in machinery and cause serious injury or death. Keep these items away from moving parts at all times to reduce this risk.

MOTORISED PLATE CURVING ROLLS

PR-133A, PR-134A, PR-136A, PR-204A

Order Code: (S802, S803, S804, S805)

EDITION : 2.0

DATE: (10/24)

The following section covers the spare parts diagrams and lists that were current at the time this manual was originally printed. Due to continuous improvements of the machine, changes may be made at anytime without notification.

HOW TO ORDER SPARE PARTS

1. Have your machines model number, serial number & date of manufacture on hand, these can be found on the specification plate mounted on the machine
2. A scanned copy of your parts list/diagram with required spare part/s identified.

NOTE: SOME PARTS MAY ONLY BE AVAILABLE AS AN ASSEMBLY

3. Go to www.machineryhouse.com.au/contactus and fill out the inquiry form attaching a copy of scanned parts list.



WARNING!

*Electricity is dangerous and could cause death
All electrical work must be carried out by a qualified electrician.*



CAUTION

It is impossible to cover all possible hazards Every workshop environment is different. These are designed as a guide to be used to compliment training and as a reminder to users prior to equipment use. Always consider safety first, as it applies to the individual working conditions.

SPARE PARTS DIAGRAM

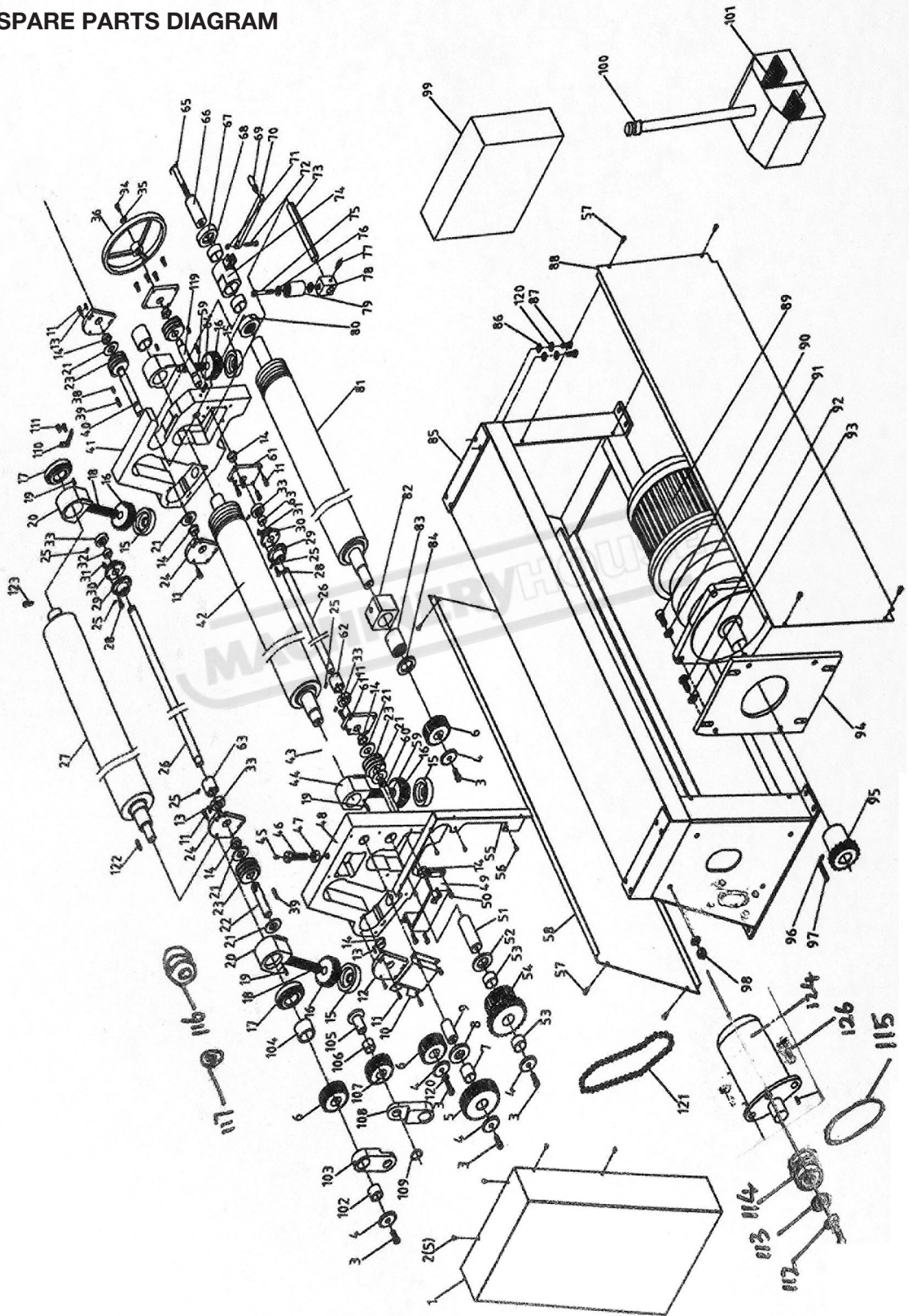

SPARE PARTS LIST

ITEM	DESCRIPTION	QTY	ITEM	DESCRIPTION	QTY.
1	PROTECTING COVER	1	50	HEX BOLT M8X25	4
2	HEX BOLT M6X10	5	51	SHAFT	1
3	BOLT M12X30	5	52	WASHER	1
4	MAT	3	53	BUSHING	2
5	BIG GEAR	1	54	CHAIN WHEEL	1
6	SMALL GEAR	3	55	CONNECTING PLATE	1
7	BUSHING	1	56	BOLT M6X12	9
8	WASHER	1	57	BOLT M8X16	8
9	SHAFT	1	58	COVER PLATE	1
10	BLOCK PLATE	1	59	SMALL SCREW ROD	2
11	HEX BOLT M6X25	40	60	CONNECTING SHAFT	1
12	FIXED PLATE	1	61	BLOCK PLATE	2
13	SPRING PIN	2	62	CONNECTING BUSHING	2
14	BUSHING	8	63	BUSHING	1
15	SUPPORTING BUSHING	3	64	LOCKING BOLT M10X30	1
16	WORM WHEEL	3	65	HEX BOLT M16X130	1
17	BEARING	2	66	HANDLE	1
18	SCREW ROD	2	67	CONNECTING BUSHING	1
19	LOCKING BOLT M6X16	4	68	BUSHING	2
20	ADJUSTING BLOCK	2	69	SWIVEL HANDLE	1
21	WASHER	8	70	POLE OF HANDLE	1
22	WORM SHAFT	1	71	LOCKING NUT M8	1
23	WORM SHAFT	4	72	HEX BOLT M8X45	1
24	BLOCK PLATE	2	73	SHAFT	1
25	HEX BOLT M6X16	8	74	LOCKING BUSHING	1
26	CONNECTING SHAFT	2	75	HEX BOLT M12X50	1
27	BACK ROLL	1	76	BEARING	2
28	KEY 6X25	4	77	HEX BOLT M10X16	1
29	CONNECTING BUSHING	2	78	SLIDING BLOCK	1
30	CONNECTING BUSHING	2	79	HEX BOLT M8X25	1
31	LOCKING NUT M6X16	8	80	SHAFT	1
32	SPRING WASHER	2	81	WASHER	1
33	CONNECTING BUSHING	3	82	BUSHING	1
34	HEX BOLT M8X20	9	83	CHAIN WHEEL	1
35	SLEEVE	1	84	CONNECTING PLATE	1
36	HANDLE WHEEL	1	85	BOLT M6X12	1
37	HEX BOLT M8X30	4	86	BOLT M8X16	8
38	KEY 8X25	2	87	COVER PLATE	8
39	KEY 8X45	2	88	SMALL SCREW ROD	1
40	WORM SHAFT	1	89	CONNECTING SHAFT	1
41	RIGHT FRAME	1	90	BLOCK PLATE	4
42	LOWER ROLLER	1	91	CONNECTING BUSHING	4
43	BUSHING	2	92	BUSHING	4
44	ADJUSTING BLOCK	2	93	LOCKING BOLT M10X30	8
45	OLI CUP	1	94	HEX BOLT M16X130	1
46	BOLT	1	95	HANDLE	1
47	NUT M20	1	96	CONNECTING BUSHING	2
48	LEFT FRAME	1	97	BUSHING	1
49	SUPPORTING PLATE	1	98	SWIVEL HANDLE	4

NOTE: SOME INDIVIDUAL PARTS MAY ONLY BE AVAILABLE AS AN ASSEMBLY

SPARE PARTS LIST

ITEM	DESCRIPTION	QTY	ITEM	DESCRIPTION	QTY.
99	ELECTRICAL BOX	1	116	BIG PULLEY	1
100	CONTROL BOX	1	117	WASHER	1
101	FOOT PEDAL	1	118	LOCKING BOLT M6X8	2
102	BEARING	1	119	WORM SHAFT	1
103	CONNECTING PLATE	1	120	SPRING WASHER	8
104	SPACER	1	121	CHAIN	1
105	SMALL SHAFT	1	122	KEY	3
106	BUSHING	1	123	OIL CUP	1
107	GEAR	1	124	ELEVATING MOTOR	1
108	CONNECTING PLATE	1	125	KEY 6X20	1
109	SPACER	1	126	HEX BOLT M10X50	4
110	SWITCH BRACKET	1	127	WASHER 10	4
111	HEX SCREW M5X12	2	128	NUT M10	4
112	HEX SCREW M6X25	2			
113	WASHER	1			
114	SMALL PULLEY	2			
115	V-BELT	2			

NOTE: SOME INDIVIDUAL PARTS MAY ONLY BE AVAILABLE AS AN ASSEMBLY



WARNING

General Machinery Safety Instructions

Machinery House
requires you to read this entire Manual before using this machine.

- 1. Read the entire Manual before starting machinery.** Machinery may cause serious injury if not correctly used.
- 2. Always use correct hearing protection when operating machinery.** Machinery noise may cause permanent hearing damage.
- 3. Machinery must never be used when tired, or under the influence of drugs or alcohol.** When running machinery you must be alert at all times.
- 4. Wear correct Clothing.** At all times remove all loose clothing, necklaces, rings, jewelry, etc. Long hair must be contained in a hair net. Non-slip protective footwear must be worn.
- 5. Always wear correct respirators around fumes or dust when operating machinery.** Machinery fumes & dust can cause serious respiratory illness. Dust extractors must be used where applicable.
- 6. Always wear correct safety glasses.** When machining you must use the correct eye protection to prevent injuring your eyes.
- 7. Keep work clean and make sure you have good lighting.** Cluttered and dark shadows may cause accidents.
- 8. Personnel must be properly trained or well supervised when operating machinery.** Make sure you have clear and safe understanding of the machine you are operating.
- 9. Keep children and visitors away.** Make sure children and visitors are at a safe distance for you work area.
- 10. Keep your workshop childproof.** Use padlocks, Turn off master power switches and remove start switch keys.
- 11. Never leave machine unattended.** Turn power off and wait till machine has come to a complete stop before leaving the machine unattended.
- 12. Make a safe working environment.** Do not use machine in a damp, wet area, or where flammable or noxious fumes may exist.
- 13. Disconnect main power before service machine.** Make sure power switch is in the off position before re-connecting.
- 14. Use correct amperage extension cords.** Undersized extension cords overheat and lose power. Replace extension cords if they become damaged.
- 15. Keep machine well maintained.** Keep blades sharp and clean for best and safest performance. Follow instructions when lubricating and changing accessories.
- 16. Keep machine well guarded.** Make sure guards on machine are in place and are all working correctly.
- 17. Do not overreach.** Keep proper footing and balance at all times.
- 18. Secure workpiece.** Use clamps or a vice to hold the workpiece where practical. Keeping the workpiece secure will free up your hand to operate the machine and will protect hand from injury.
- 19. Check machine over before operating.** Check machine for damaged parts, loose bolts, Keys and wrenches left on machine and any other conditions that may effect the machines operation. Repair and replace damaged parts.
- 20. Use recommended accessories.** Refer to instruction manual or ask correct service officer when using accessories. The use of improper accessories may cause the risk of injury.
- 21. Do not force machinery.** Work at the speed and capacity at which the machine or accessory was designed.
- 22. Use correct lifting practice.** Always use the correct lifting methods when using machinery. Incorrect lifting methods can cause serious injury.
- 23. Lock mobile bases.** Make sure any mobile bases are locked before using machine.
- 24. Allergic reactions.** Certain metal shavings and cutting fluids may cause an allergic reaction in people and animals, especially when cutting as the fumes can be inhaled. Make sure you know what type of metal and cutting fluid you will be exposed to and how to avoid contamination.
- 25. Call for help.** If at any time you experience difficulties, stop the machine and call you nearest branch service department for help.

WARNING

Motorised Sheetmetal Rolling Machine Safety Instructions

Machinery House
requires you to read this entire Manual before using this machine.

- 1. Maintenance.** Make sure the Rolling machine is turned off and disconnect from the main power supply and make sure all moving parts have come to a complete stop before any inspection, adjustment or maintenance is carried out.
- 2. Rolling machine Condition.** Rolling machine must be maintained for a proper working condition. Never operate a Rolling machine that has damaged or worn parts. Scheduled routine maintenance should be performed on a scheduled basis.
- 3. Roll Condition.** Never operate a Rolling machine with a damaged or badly worn Rolls. Replace if required. Rolls should never be greased or lubricated as rolls will slip the material and will not bend.
- 4. Roll Direction.** Be aware of the correct Rotational axis of the motor when a qualified electrician connects the machine.
- 5. Hand Hazard.** Keep hands and fingers clear from moving parts. Serious injury can occur if hand or finger tips get pinched by rolls and can be dragged into machine.
- 6. Personal Protection.** Gloves, safety glasses and safety hat are recommended during operation.
- 7. Avoiding Entanglement.** Rolling machine guards must be used at all times. Tie up long hair and use the correct hair nets to avoid any entanglement with the Rolling machine moving parts.
- 8. Understand the machines controls.** Make sure you understand the use and operation of all controls.
- 9. Trained Operator.** This machine must be operated by authorized and trained personnel.
- 10. Power outage.** In the event of a power failure during use of the machine, turn off all switches to avoid possible sudden start up once power is restored.
- 11. Work area hazards.** Keep the area around the Rolling machine clean from oil, tools, chips. Pay attention to other persons in the area and know what is going on around the area to ensure unintended accidents.
- 12. Guards.** Do not operate Rolling machine without the correct guards in place. Necessary guards protect you from injuries by worm-type gearbox and other gears. The only other area which needs to be carefully monitored during use is the rotational area of the rolls.
- 13. Material condition.** Material must be clean out of oil and dry. Oily material can slip and will not bend.
- 14. Material hardness.** Make sure your hardness is the same throughout the material, we recommend that you use certified material. Never bend hard steel, glass or fragile material on this machine.
- 15. Feeding material.** Making a tight bend in one pass is not possible. So you need several passes before you can achieve a certain radius. Tighter curves and full radius always need more passes.
- 16. Stopping the Rolls.** Do not stop or slow the rolls with your hand or workpiece. Allow the Rolling machine to stop on its own.
- 17. Emergency stop.** Use the emergency stop button in case of any emergency.
- 18. Hearing protection and hazards.** Always wear hearing protection as noise generated from machine and workpiece can cause permanent hearing loss over time.
- 19. Call for help.** If at any time you experience difficulties, stop the machine and call your nearest branch service department for help.

PLANT SAFETY PROGRAM

NEW MACHINERY HAZARD IDENTIFICATION, ASSESSMENT & CONTROL

Motorised Sheetmetal Rolling Machine

Developed in Co-operation Between A.W.I.S.A and Australia Chamber of Manufactures
This program is based upon the Safe Work Australia, Code of Practice - Managing Risks of Plant in the Workplace (WHSA 2011 No10)

Item No.	Hazard Identification	Hazard Assessment	Risk Control Strategies <small>(Recommended for Purchase / Buyer / User)</small>
A	ENTANGLEMENT	HIGH	Eliminate, avoid loose clothing / Long hair etc.
B	CRUSHING	LOW	Secure & support work material. Ensure machine is bolted down.
C	CUTTING, STABBING, PUNCTURING.	MEDIUM	Isolate power to machine prior to any checks or maintenance being carried out. Do not adjust or clean until the machine has fully stopped. Wear gloves to prevent cuts from material.
D	SHEARING	MEDIUM	Isolate power to machine when checks or maintenance is being carried out. Make sure all guards are secured shut when machine is on. Hands should be kept clear of moving parts such as rolls etc.
F	STRIKING	MEDIUM	Ensure area is kept clear of material being rolled.
H	ELECTRICAL	MEDIUM	All electrical enclosures should only be opened with a tool that is not to be kept with the machine. Machine should be installed & checked by a Licensed Electrician.
O	OTHER HAZARDS, NOISE.	LOW	Wear hearing protection as required.
Plant Safety Program to be read in conjunction with manufactures instructions			



www.machineryhouse.com.au



www.machineryhouse.co.nz

Authorised and signed by:
Safety officer:

 Manager:

Revised Date: 12th March 2012

NOTES

MACHINERYHOUSE

MACHINERYHOUSE



ENVIRONMENT PROTECTION

Recycle unwanted materials instead of disposing of them as waste. All tools, accessories and packaging should be sorted, taken to a recycling centre and disposed of in a manner which is compatible with the environment. When the product becomes completely unserviceable and requires disposal, drain any fluids (if applicable) into approved containers and dispose of the product and fluids according to local regulations.

IMPORTED BY



Australian Distributor

**Hare & Forbes
Machineryhouse**
Sydney - Melbourne
Adelaide - Brisbane - Perth

Ph: 1300 202 200
www.machineryhouse.com.au



New Zealand Distributor

Machineryhouse
Auckland
Christchurch

Ph: 0800 142 326
www.machineryhouse.co.nz